

Electricity

Page 1

START

Key Words:

- Conductor** A material or object that allows electricity to flow through it.
- Insulator** A material or object that does not allow electricity to flow through it.
- Ohmic conductor** a conductor that obeys Ohm's Law.
- Current** The rate of flow of electrical charge around a circuit.
- Potential Difference (P.d)** A measure of work done. Makes the current flow.
- Resistance** Opposes the electric current.
- Thermistor** A temperature dependent resistor
- LDR** A light dependent resistor.
- Diode** A component that allows current to flow in only one direction.
- Power** The rate that energy is transferred.
- Alternating P.d** Voltage that changes from positive to negative.
- Direct P.d** Voltage that pushes the current in one direction.
- National Grid** A system of cables & transformers that connect power stations to consumers.
- Transformer** A device that increases or decreases P.d.

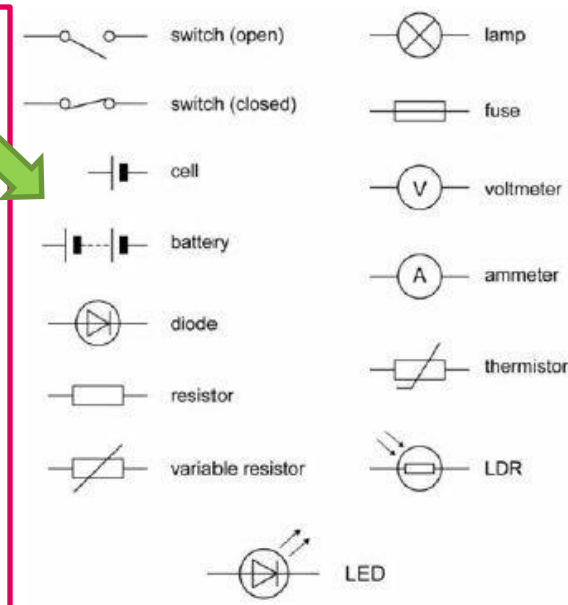

The **total resistance** in a **parallel** circuit is the reciprocals of all of the resistances.

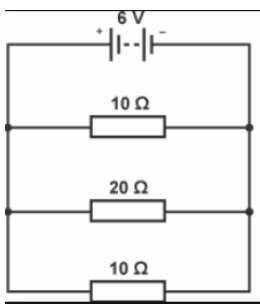

e.g. $\frac{1}{R_{Total}} = \frac{1}{10} + \frac{1}{20} + \frac{1}{10} = 0.25$

This answer is 1 divided by the total resistance so we need to do 1 divided by our answer:
 $1 \div 0.25 = 4\Omega$
 4Ω is the total resistance for this circuit. Use your scientific calculator to add the fractions!

The **total resistance** in a **series** circuit is the sum of the resistors in the circuit

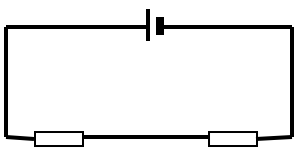

e.g. $6 + 10 = 16\Omega$

A **variable resistor** can alter the resistance in a circuit and is useful for things like controlling volume or light dimmer switches. LDRs **decrease** resistance when there is bright light. Thermistors **decrease** resistance when it gets warmer.

- P.d. is measured using a **voltmeter** connected in parallel across a component.
- In a series circuit the P.d of the cells or battery is shared between the components.
- In a parallel circuit the P.d. across each branch is equal to the P.d. across the cell.

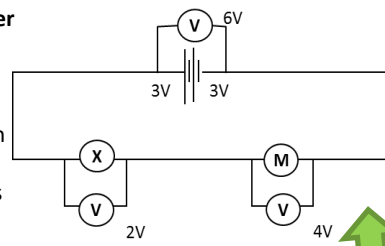

- Current is measured using an Ammeter in series with the circuit.
- In a series circuit the current is the same everywhere.
- In a parallel circuit the current is split when it reaches a branch.
- The circuit needs to be complete for the current to flow.

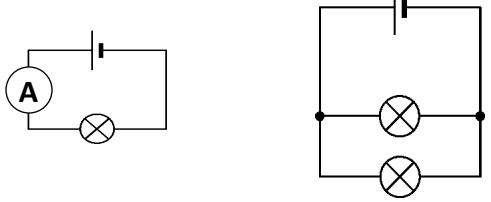

Charge = Current × time	$Q = I t$
P.d. = Current × Resistance	$V = I R$
Power = P.d. × Current	$P = V I$
Power = (Current) ² × Resistance	$P = I^2 R$
Energy = Power × time	$E = P t$
Energy = Charge × P.d	$E = Q V$

LEARN & USE THE UNITS:

Charge	Coulombs (C)
Current	Amps (A)
P.d.	Volts (V)
Resistance	Ohms (Ω)
Power	Watts (W)
Energy	Joules (J)
Time	Seconds (s)

Electricity

Page 2

The current through a **resistor** (at a constant temperature) is directly proportional to the P.d across it.

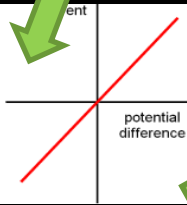

The resistance of a **bulb** increases as the temperature of the filament increases

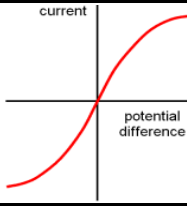

The current through a **diode** flows in one direction. It has a very high resistance in the opposite direction.

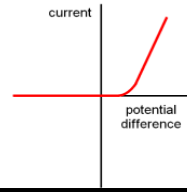

The National Grid

- Electricity is transferred from power stations to consumers along cables of the National Grid.
- When a current flows through a wire some energy is lost as heat. The higher the current, the more heat is lost.
- To reduce these losses, the National Grid transmits electricity at a low current. This needs a high voltage.
- Power stations produce electricity at 25,000V. Electricity is sent through the National Grid cables at 400,000V, 275,000V and 132,000V.
- Step-up transformers are used at power stations to produce the very high voltages needed to transmit electricity through the National Grid power lines.
- These high voltages are too dangerous to use in the home, so step-down transformers are used locally to reduce the voltage to safe levels.

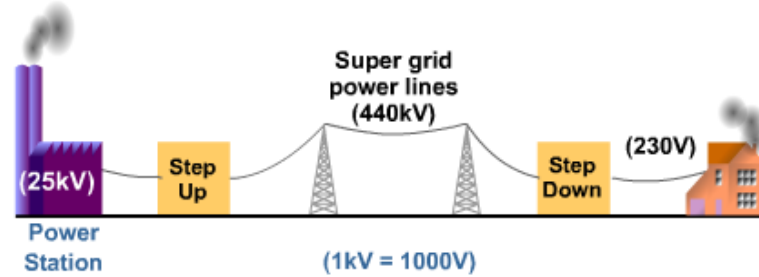

Household electricity has a potential difference of around **230V** and a frequency of **50 Hz (Hertz)**, so changes direction 50 times in a second.

Direct current (DC) only flows in one direction, whereas current from the mains supply is **alternating current (AC)** because it alters direction.

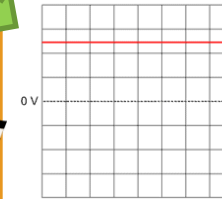

DC- one direction

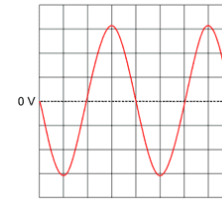

AC- alternating direction

- Blue is neutral and goes on the left
- Green/yellow is Earth and goes to the top
- Brown is live and goes to the right
- A fuse will melt & break the circuit when the current is too high.

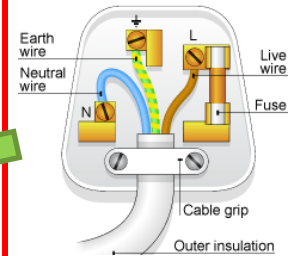

The circuits in your house are earthed outside. Appliances with metal cases need to be earthed inside the case.

This is just in case a live wire comes loose- the current will then pass through the earth wire and not you when you touch it.

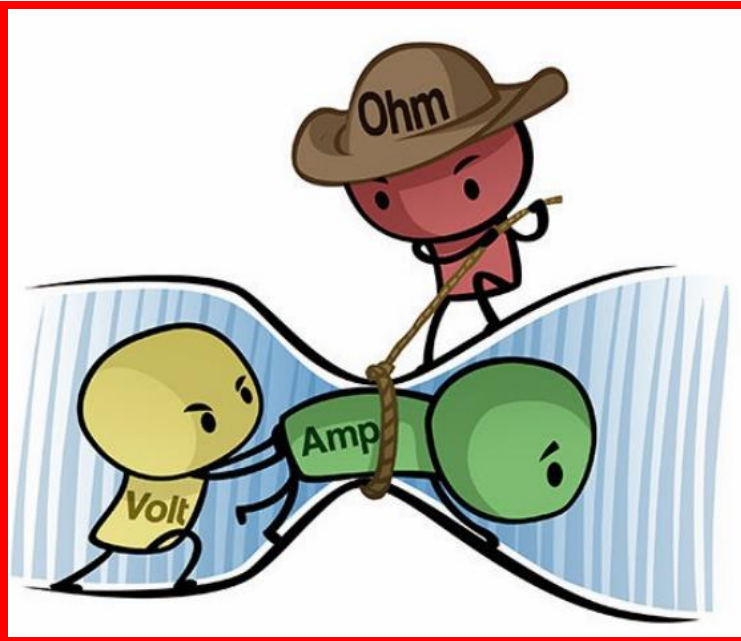
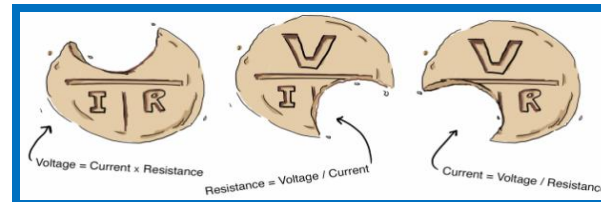
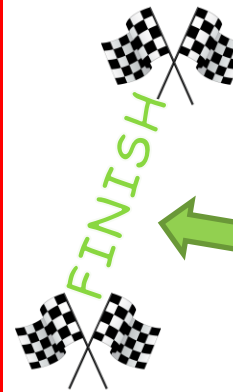

ELECTRICITY

1. Draw a circuit diagram to show how the P.d and current of a bulb can be investigated.
2. Draw the V-I characteristic graphs for: (a) an Ohmic conductor (b) a diode (c) a filament bulb.
3. Explain why the V-I graph for the bulb is the shape that it is.
4. What is the unit of charge?
5. If a current of 4A flow for 30s how much charge will flow?
6. If 60Ω resistor has a P.d of 12V put across it, how much current will flow?
7. Calculate the missing voltages in the circuits below:

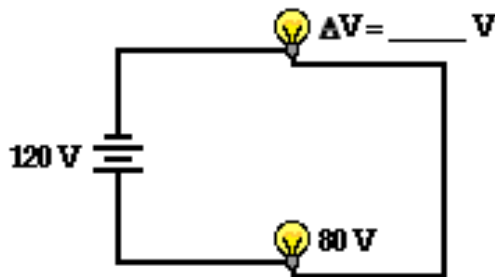

Diagram A

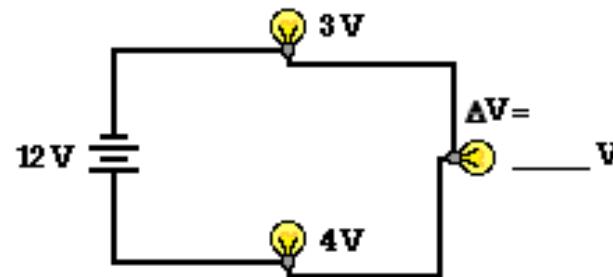
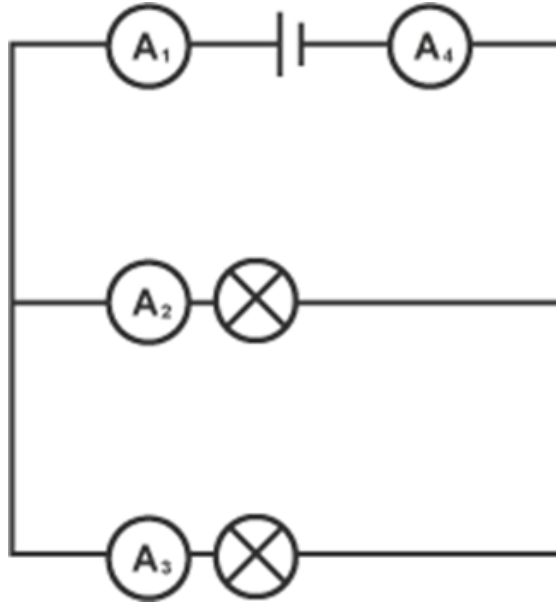

Diagram B

8. How much current will flow through a hairdryer that has a power rating of 2kW when it is plugged into the 230V mains supply?

ELECTRICITY

8. The current through $A_1 = 6A$ and the current through $A_2 = 4A$ What is the current through A_3 and A_4 ?



9. What is the power of a bulb that has a resistance of 200Ω when a current of $0.2A$ flow through it?
10. Draw a labelled diagram of a 3-pin plug.
11. What is the function of the Earth wire?
12. Draw a labelled diagram of the National Grid.
13. Why is the P.d. increased to over $400kV$ for transmitting electricity across the national grid?
14. Explain what potential difference, current and resistance are in words.